

# PalletPro™ 70



## Parts Reference Guide



Repair Kit  
YK0447

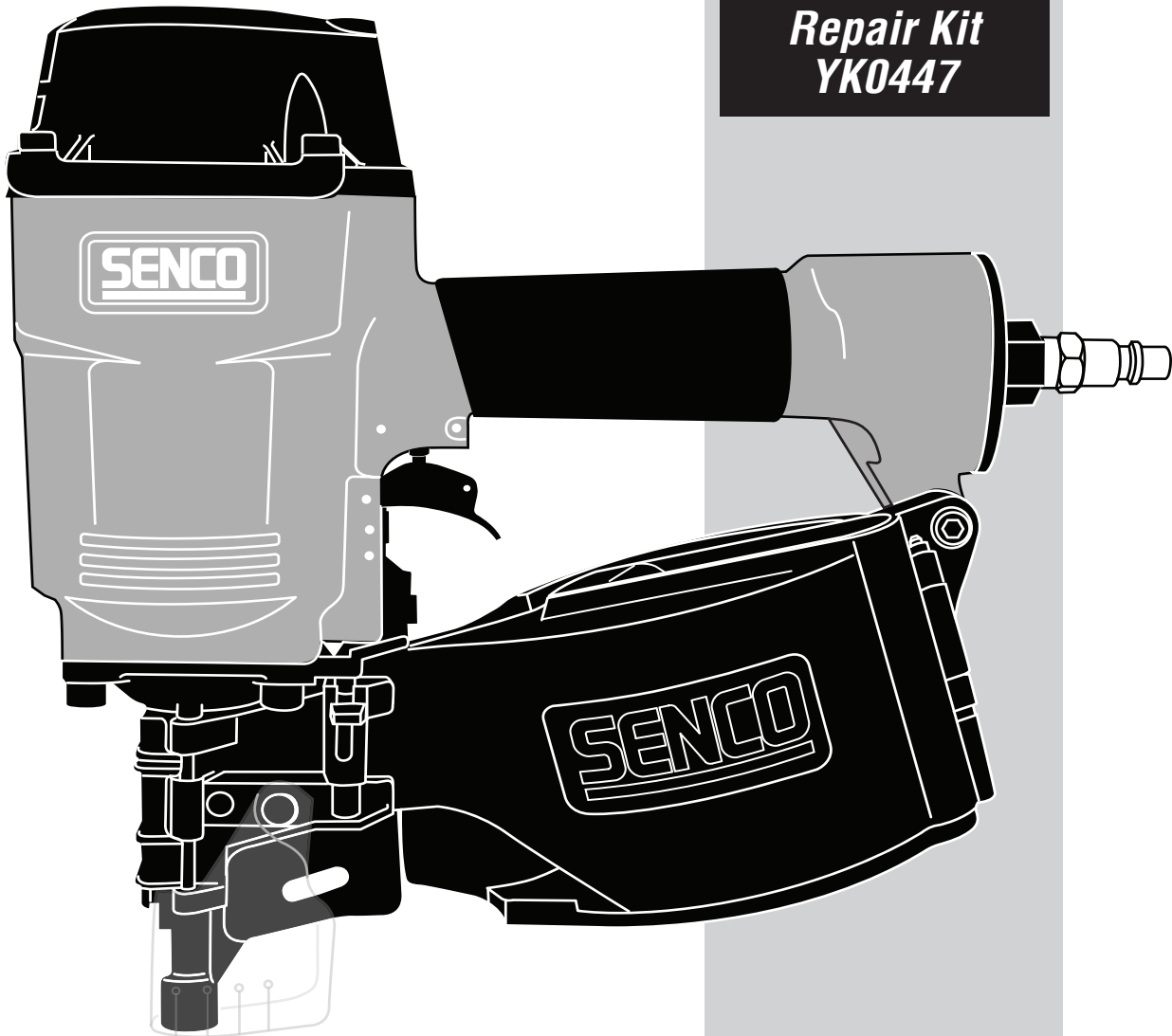

\* Schematic drawings inside

Senco Products Inc.  
8485 Broadwell Road  
Cincinnati, Ohio 45244  
Visit Our Website: [www.senco.com](http://www.senco.com)

Questions? Comments? call SENCO's toll-free Action-line:  
1-800-543-4596 (North and South America Only)  
or e-mail: [toolprof@senco.com](mailto:toolprof@senco.com)

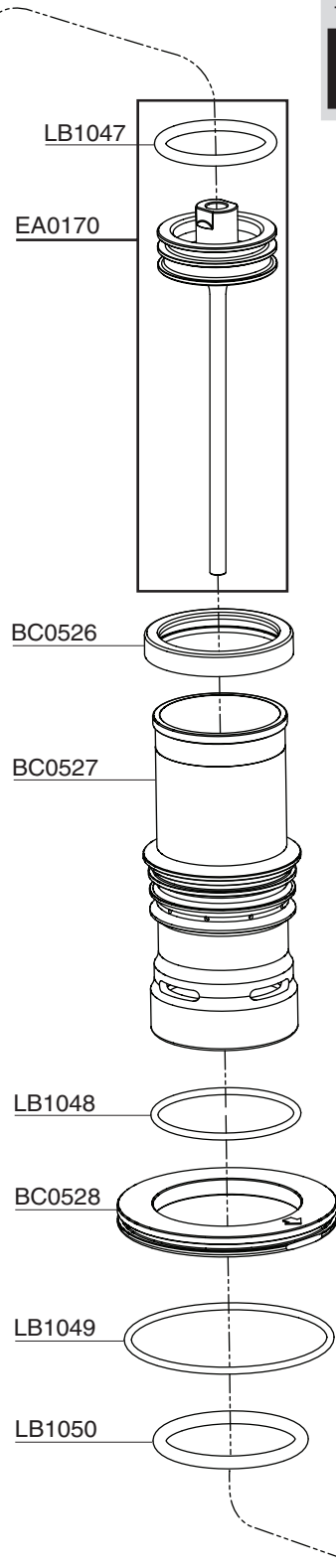
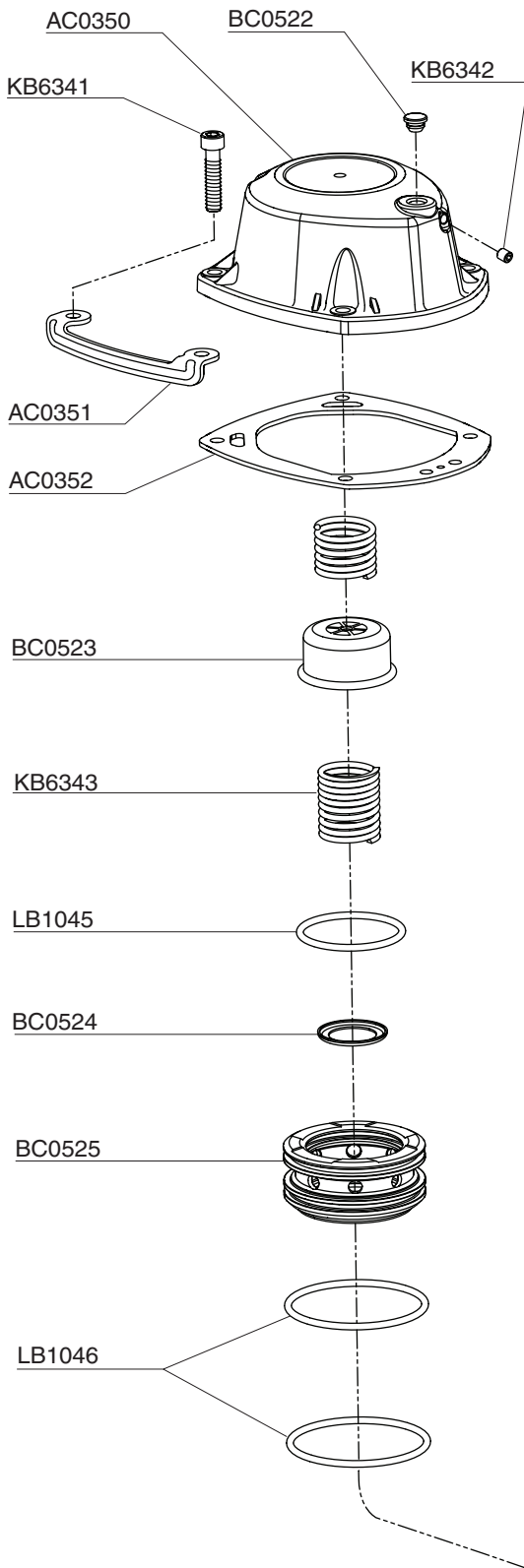

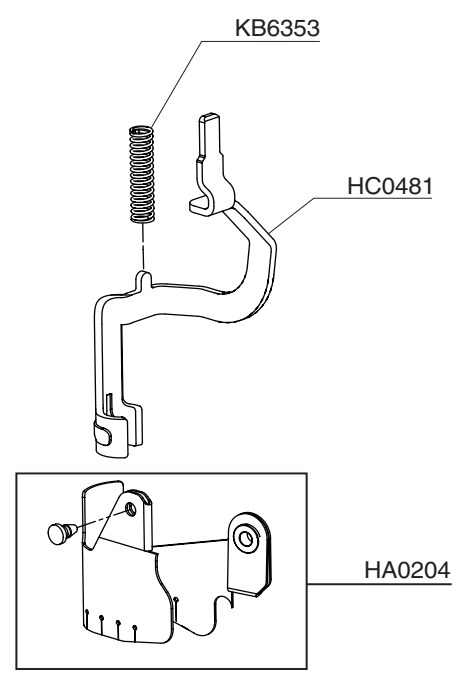
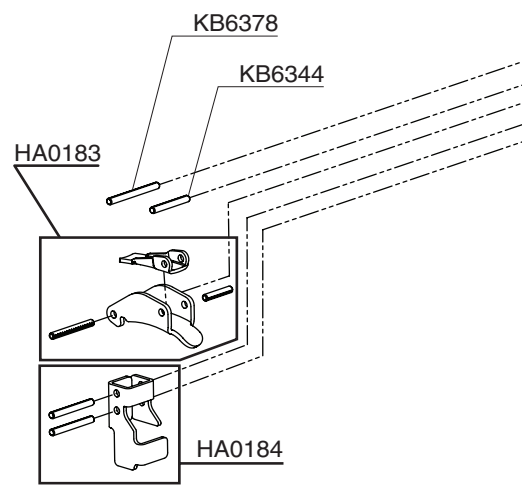

Tool #	Model
4M0001N	Contact Actuation
4M2001N	Contact Actuation

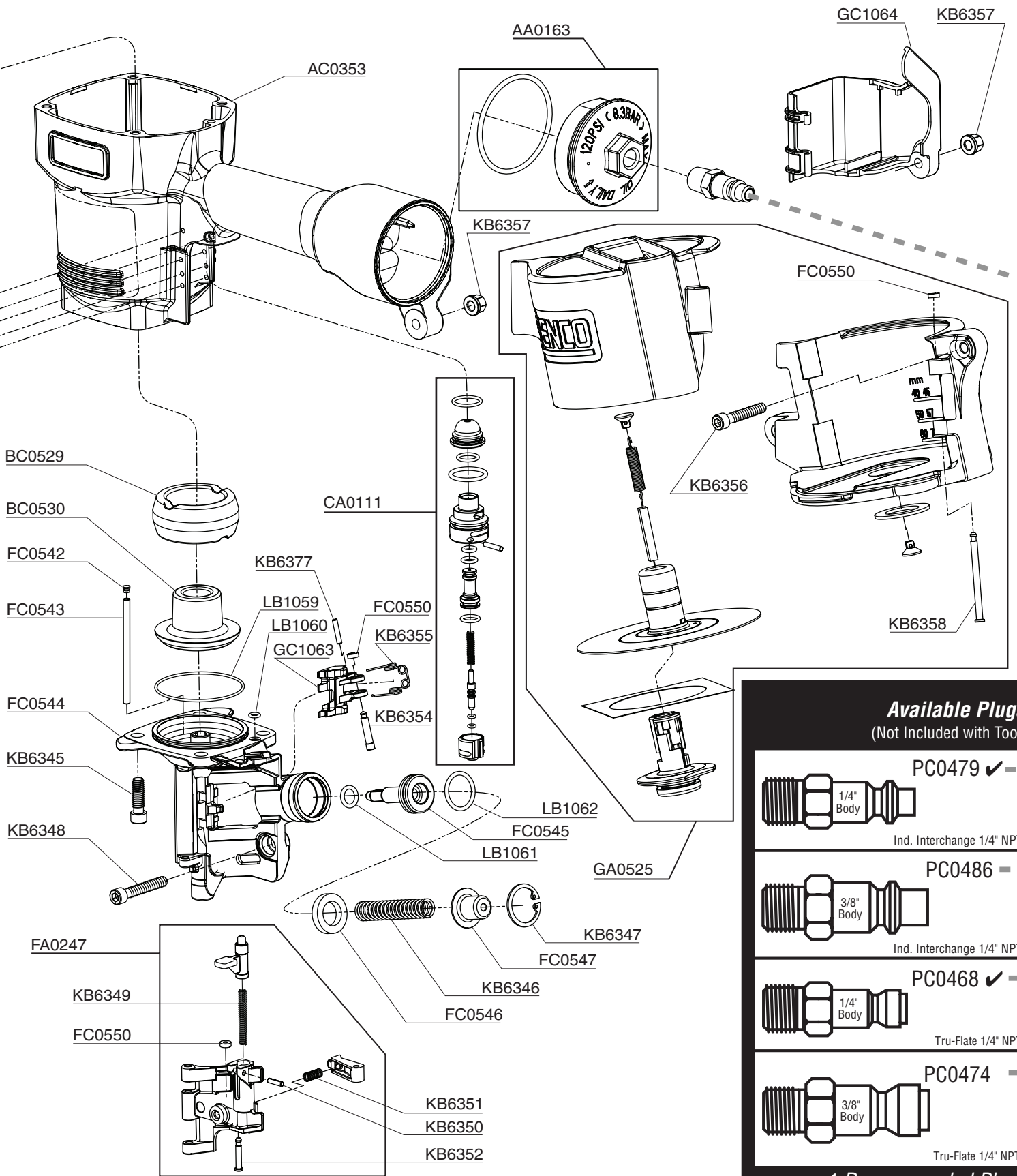

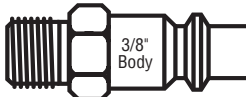

NFG04M Revised January 20, 2009 (Replaces 7/29/08) © 2007, 2009 by SENC0 Products, Inc. Cincinnati, Ohio 45244 - U.S.A.

**Available Plugs**  
(Not Included with Tool)

	<b>PC0479</b> ✓
	1/4" Body
	Ind. Interchange 1/4" NPT
	<b>PC0486</b>
	3/8" Body
	Ind. Interchange 1/4" NPT
	<b>PC0468</b> ✓
	1/4" Body
	Tru-Flate 1/4" NPT
	<b>PC0474</b>
	3/8" Body
	Tru-Flate 1/4" NPT

✓ **Recommended Plugs**  
Plugs shown smaller than actual size

# PalletPro™ 70

REPLACEMENT PARTS LIST • LISTA DE PARTES DE REPUESTO • ERSATZTEILE-LISTE • LISTE DE PIÈCES DE RECHANGE

PART NO.	DESCRIPTION	DESCRIPCIÓN	BESCHREIBUNG	DÉSIGNATION
AA0163	CAP ASY	ASAMBLE DE TAPA	KAPPE-ZUSAMMENBAU	BOUCHON D'ASSEMBLÉE
AC0350	CAP	TAPA	KAPPE	BOUCHON
AC0351	WEAR GUARD	PLACA	SCHUTZPLATTE	BOUCLIER ANTIABRASIF
AC0352	SEAL	SELLO	DICHTUNG	JOINT
AC0353	MAIN BODY	CARCASA	GEHÄUSE	CORPS
BC0522	RETAINER	JUNTA TÓRICA	SICHERUNGSRING	RETENUE
BC0523	SEAL	SELLO	DICHTUNG	JOINT
BC0524	WASHER	ARANDELA	SCHLEIBE	RONDELLE
BC0525	VALVE	VALVULA	VENTIL	VALVE
BC0526	CYLINDER COLLAR	CILINDRO	ZYLINDER	CYLINDRE
BC0527	CYLINDER	CILINDRO	ZYLINDER	CYLINDRE
BC0528	SPACER	SEPARADOR	DISTANZSTÜCK	ENRETOISE
BC0529	STOP	TOPPE	PUFFER	ARRÊT
BC0530	STOP	TOPPE	PUFFER	ARRÊT
CA0111	VALVE ASSEMBLY	ASAMBLE DE VALVULA	VENTIL-ZUSAMMENBAU	VALVE D'ASSEMBLÉE
EA0170	DRIVER ASSY	PERCUSOR	TREIBER	COUTEAU
FA0247	LATCH ASY	ASAMBLE DE UNETA	VERSCHLUSS-ZUSAMMENBAU	DOIGT DE RETUNUE D'ASSEMBLÉE
FC0542	RETAINER	JUNTA TÓRICA	SICHERUNGSRING	RETENUE
FC0543	PIN	PASADOR	STIFT	GOUPILLE
FC0544	GUIDE BODY	PLACA DE NARIZ	NAGELFUHRUNG	FRONT
FC0545	PISTON	PISTON	KOLBEN	PISTON
FC0546	STOP	TOPPE	PUFFER	ARRÊT
FC0547	CAP	TAPA	KAPPE	BOUCHON
FC0550	RETAINER	RETEN	SICHERUNGSRING	RETENUE
GA0525	MAGAZINE ASY	ASAMBLE DE CARGADOR	MAGAZIN-ZUSAMMENBAU	MAGASIN D'ASSEMBLÉE
GC1063	FEED PAWL	ALIMENTADOR	VORSCHIEBER	POUSSOIR
GC1064	COVER	CUBIERTA	ABDECKUNG	COUVERCLE
HA0183	TRIGGER ASSEMBLY	ASAMBLE DE GATILLO	AUSLÖSER-ZUSAMMENBAU	GÂCHETTE D'ASSEMBLÉE
HA0184	SAFETY ELEMENT ASSEMBLY	ASAMBLE DE SEGURO	SICHERHEITSVORRICHTUNG-ZUSAMMENBAU	ENSEMBLE PALPEUR DE SÉCURITÉ
HA0204	COVER ASY	ASAMBLE DE CUBIERTA	ABDECKUNG-ZUSAMMENBAU	COUVERCLE D'ASSEMBLÉE
HC0481	SAFETY ELEMENT	SEGURO	SICHERHEITSVORRICHTUNG	PALPEUR DE SÉCURITÉ
KB6341	SCREW	TORNILLO	SCHRAUBE	VIS
KB6342	SCREW	TORNILLO	SCHRAUBE	VIS
KB6343	SPRING	RESORTE	FEDER	RESSORT
KB6344	PIN	PASADOR	STIFT	GOUPILLE
KB6345	SCREW	TORNILLO	SCHRAUBE	VIS
KB6346	SPRING	RESORTE	FEDER	RESSORT
KB6347	RETAINER	RETEN	SICHERUNGSRING	RETENUE
KB6348	SCREW	TORNILLO	SCHRAUBE	VIS
KB6349	SPRING	RESORTE	FEDER	RESSORT
KB6350	PIN	PASADOR	STIFT	GOUPILLE
KB6351	SPRING	RESORTE	FEDER	RESSORT
KB6352	PIN	PASADOR	STIFT	GOUPILLE
KB6353	SPRING	RESORTE	FEDER	RESSORT
KB6354	PIN	PASADOR	STIFT	GOUPILLE
KB6355	SPRING	RESORTE	FEDER	RESSORT
KB6356	SCREW	TORNILLO	SCHRAUBE	VIS
KB6357	NUT	TUERCA	MUTTE	ECROU
KB6358	PIN	PASADOR	STIFT	GOUPILLE
KB6377	PIN	PASADOR	STIFT	GOUPILLE
KB6378	PIN	PASADOR	STIFT	GOUPILLE
LB1045	SEAL	SELLO	DICHTUNG	JOINT
LB1046	SEAL	SELLO	DICHTUNG	JOINT
LB1047	SEAL	SELLO	DICHTUNG	JOINT
LB1048	SEAL	SELLO	DICHTUNG	JOINT
LB1049	SEAL	SELLO	DICHTUNG	JOINT
LB1050	SEAL	SELLO	DICHTUNG	JOINT
LB1059	SEAL	SELLO	DICHTUNG	JOINT
LB1060	SEAL	SELLO	DICHTUNG	JOINT
LB1061	SEAL	SELLO	DICHTUNG	JOINT
LB1062	SEAL	SELLO	DICHTUNG	JOINT